

GPE-TURBO – WHO WE ARE

Your equipment will never be in safer hands.

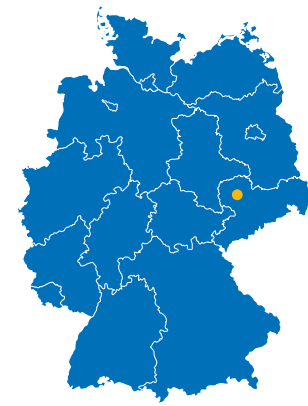

German Pneumatics Engineering GmbH was established in Leipzig 2013 as Original Equipment Manufacturer for turbo compressor units. We are experts for the development of new machines, the maintenance, the supply of spare parts and the reconditioning of existing machines.

We stand out with fast responses, with customized solutions, with the ability to build fully API compliant and tailor-made-machines.

Our experts are at your disposal with many years of experience, established engineering knowledge and ability to react quickly. With an already global reference list, we travel around the world supplying and supporting compressors in multiple sectors helping keep the wheels of industry turning.



Leipzig – Dubai – Bahrain – Moscow – Beijing – São Paulo

TURBO COMPRESSOR SUPPLIER AND SERVICE PARTNER WORLDWIDE

Innovation and Competence - German Quality worldwide



Management Service

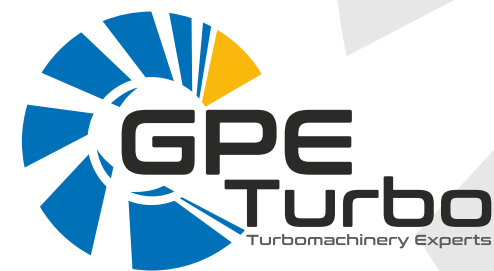

German Pneumatics Engineering GmbH
Arthur-Winkler-Straße 67
04319 Leipzig / Germany

FON: +49 341 58 303 810
MAIL: leipzig@gpe-turbo.de
www.gpe-turbo.de



TURBO COMPRESSORS - OUR PERFORMANCE

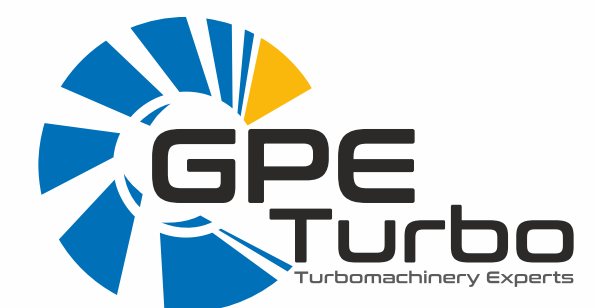
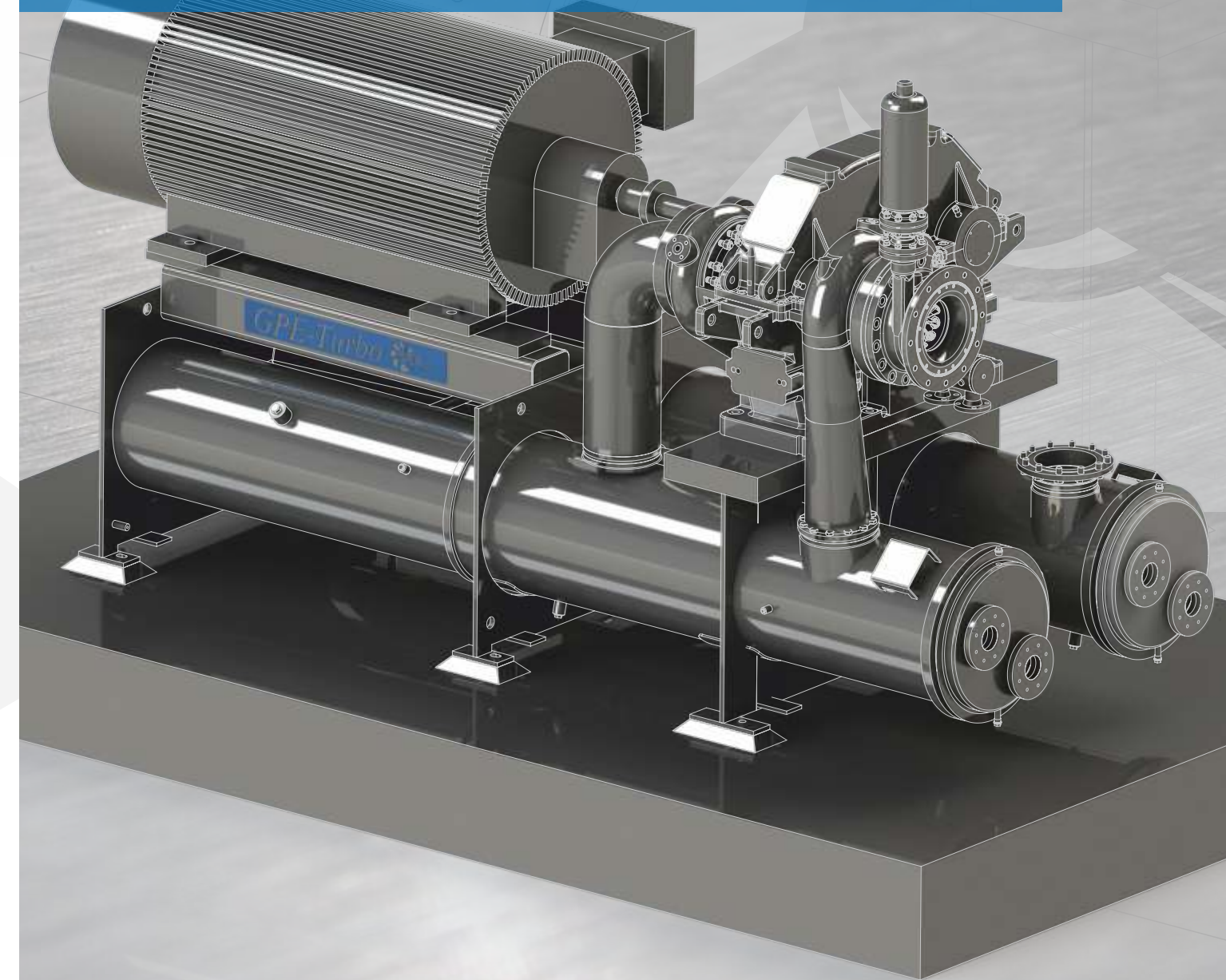

German Pneumatics Engineering GmbH

GPE TURBO COMPRESSORS

We offer reliable solutions based on experience.

- Complete compressor solutions
- Main components sourced in Germany
- Dynamic balancing in our workshop
- High speed balancing with our partners
- In house assembly and testing
- Engineered solutions for gas sealings
- PLC programming & software modifications



EXPERIENCE IN AIR AND PROCESS GAS COMPRESSION

We operate in any terrain and with any gas.

- Onshore
- Offshore
- Tropic
- Desert
- Hydrocarbon mixtures
- Hydrogen
- Sour gas and others
- Air

■ 30 years plant life

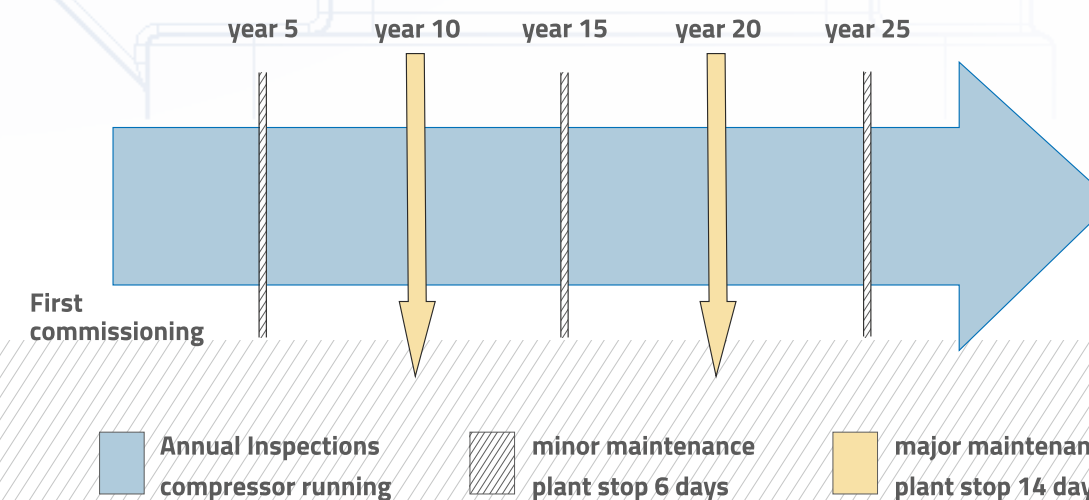

COMPRESSOR OPTIONS

We design the right compressor for your plant.

■ Compact and predesigned compressors

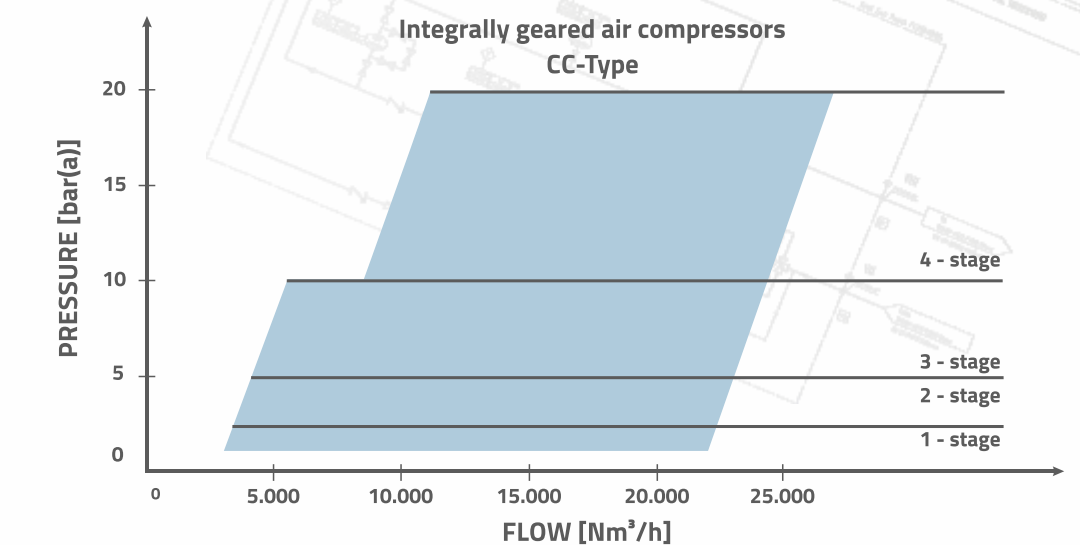

■ Tailor-made-compressors

